

構造図 STRUCTURE and MATERIAL

リードタイプ円板型セラミックコンデンサ Lead Type Disc Ceramic Capacitors <DE* Series>

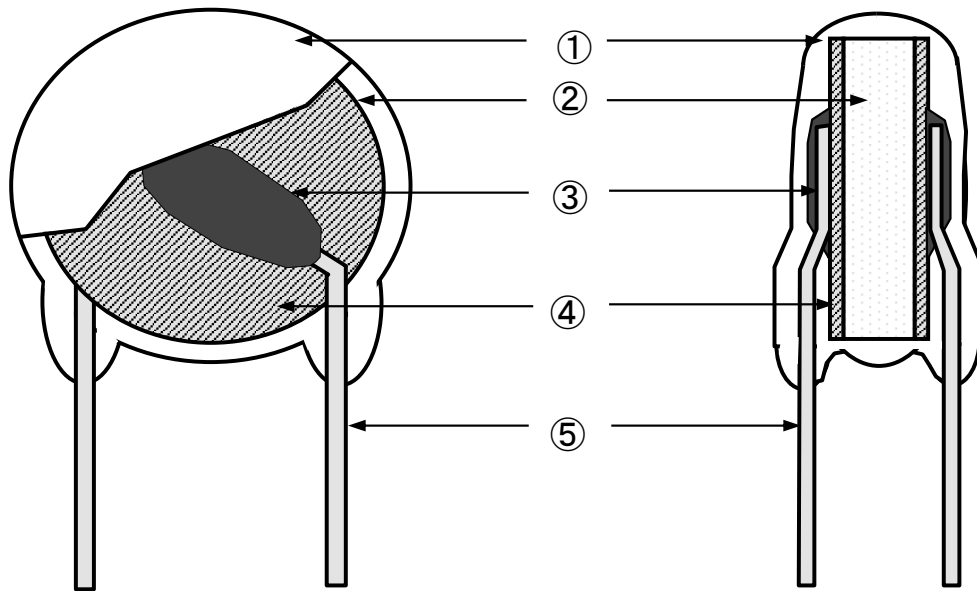

No.	構成材 Material	材料名 Description
①	外装材料 Enclosure	エポキシ系絶縁塗料 (UL94V-0取得) Epoxy resin (Conforming to UL94V-0 standard)
②	誘電体 Dielectric	磁器素体 Ceramic
③	はんだ Solder	錫-銅系はんだ Tin-Copper alloy
④	電極 Electrode	銅 Copper
⑤	リード線 Lead wire	錫-銅系はんだ引き銅線 Solder coated copper wire (Solder : Tin-Copper alloy)