

Feature

1. Ultra Small SMD package (1.35x1.05mm package)
2. High Attenuation (at 843 to 870 MHz ; 50 dB min.)
3. Low Insertion Loss (2.2 dB max.)

Test Circuit

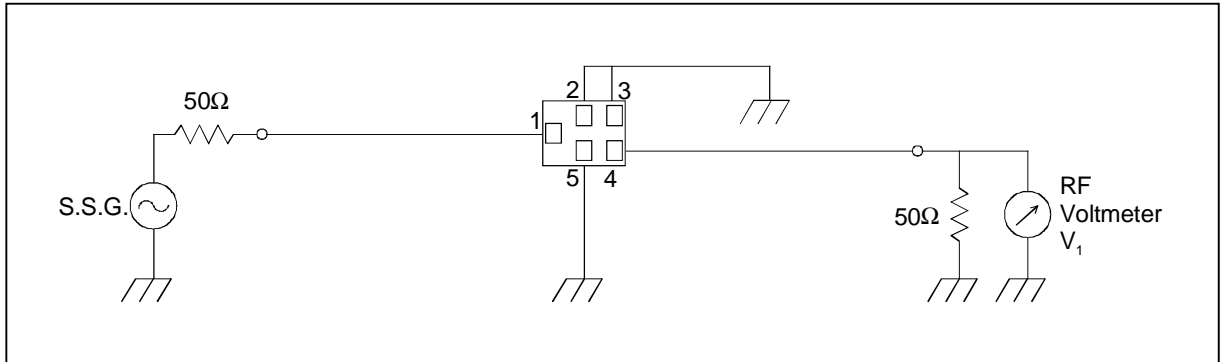

Package Dimensions

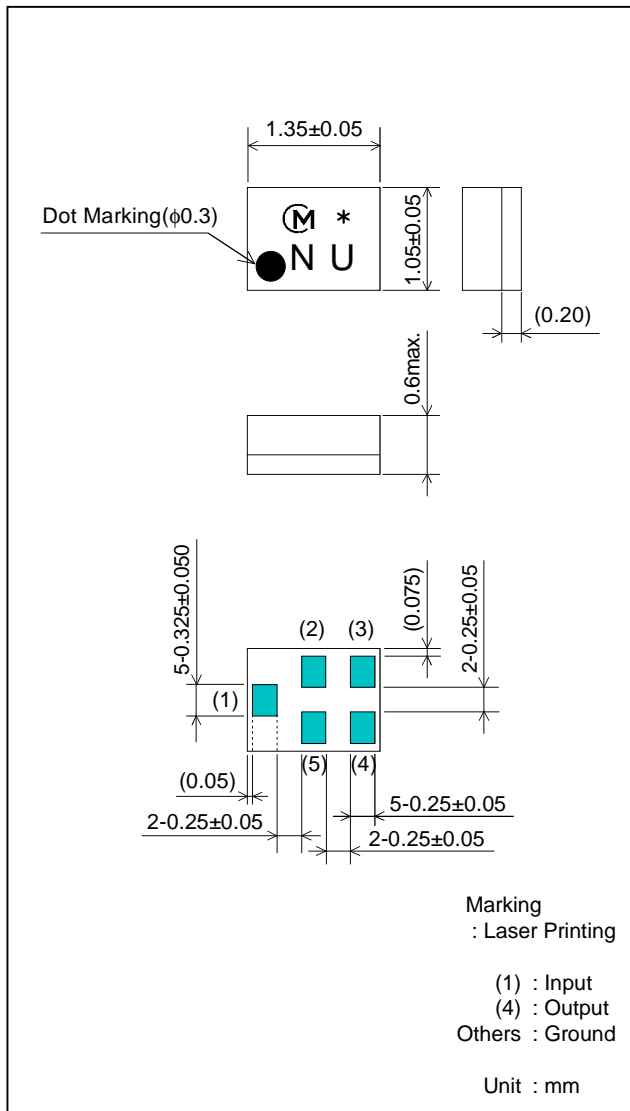

Specification

Item	Specification	
	-30 to +85°C	typ.
Nominal Center Frequency(f_c)	911.5 MHz	
Insertion Loss (898 to 925 MHz)	2.2 dB max.	1.6 dB
Absolute Attenuation		
1) 720 to 800 MHz	57 dB min.	65 dB
2) 843 to 870 MHz	50 dB min.	61 dB
3) 940 to 2000 MHz	9 dB min.	18 dB
4) 2000 to 3000 MHz	36 dB min.	44 dB
Ripple Deviation (898 to 925 MHz)	1.2 dB max.	0.4 dB
VSWR (898 to 925 MHz)	2.0 max.	1.5
Input/Output Impedance (nominal)	50Ω	

■ Frequency Performance

